

ORIGINAL INSTRUCTIONS - according to Directive 2006/42/EC, Annex I 1.7.4.1

OPERATOR'S MANUAL

JF-Link
Mixer

CONTENTS

| | |
|---|-----------|
| 1. JF-LINK WIRELESS ELECTRICAL OPERATION OF HYDRAULICS | 5 |
| VALVE BOX | 5 |
| PROGRAMMING OF REMOTE CONTROL | 7 |
| REMOTE CONTROLS | 9 |
| Tractor remote control..... | 9 |
| Display..... | 9 |
| Hand remote control..... | 9 |
| FUNCTIONS..... | 11 |
| Proportional steering | 11 |
| Blocking of axle with articulation | 13 |
| Macro programs..... | 13 |
| 2. MACRO SYSTEM | 15 |
| PROGRAMMING | 15 |
| 3. OPERATION VARIANTS | 17 |
| KONGSKILDE FEEDER COMPLETE DIET MIXERS "VM" | 17 |
| Side doors..... | 17 |
| Hydraulic shearbars | 17 |
| Hydraulic jack..... | 17 |
| Cross conveyor | 17 |
| Elevator..... | 19 |
| Gear change | 19 |
| KONGSKILDE FEEDER COMPLETE DIET MIXERS "PA" | 21 |
| Side door..... | 21 |
| Hydraulic tipping of tub..... | 21 |
| Discharge with roller..... | 21 |
| Elevator..... | 21 |
| Hydraulic jack..... | 21 |
| 4. MISCELLANEOUS | 23 |
| INTERRUPTIONS | 23 |
| HYDRAULIC DIAGRAM | 23 |

1. JF-LINK WIRELESS ELECTRICAL OPERATION OF HYDRAUALICS

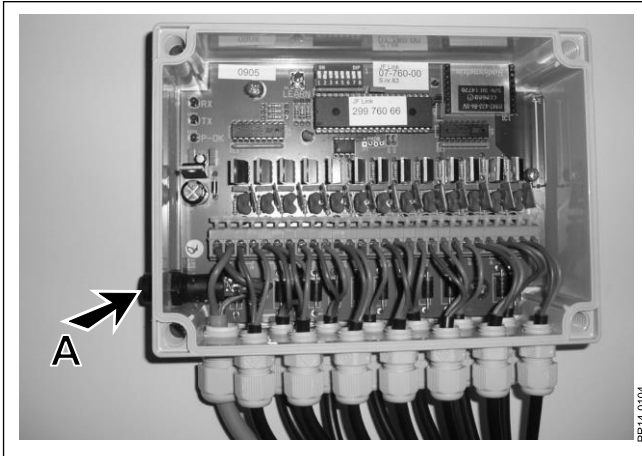

Fig. 1.1

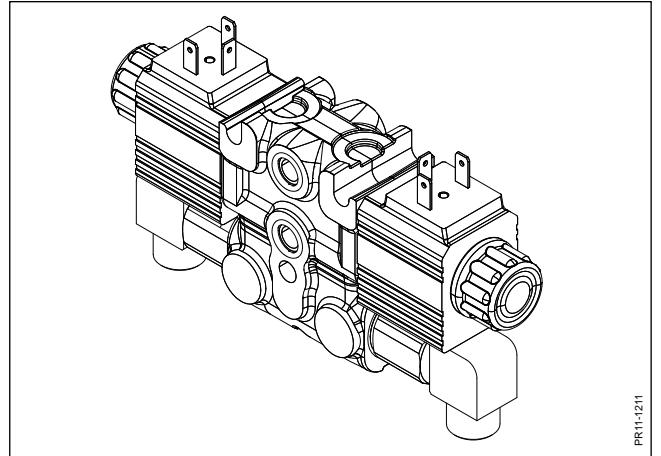

Fig. 1.2

1. JF-LINK WIRELESS ELECTRICAL OPERATION OF HYDRAULICS

JF-Link is a wireless remote control system for control of electrically operated hydraulics. The remote control operates by means of radio signals. The signals are an individual frequency unique for each single machine. Therefore, a JF-Link remote control cannot unintentionally disturb other radio based systems, even though they are within the reach of each other. In the same way, JF-Link cannot be disturbed by other radio sources. Two (or more) JF-Link systems working close together will not interrupt each other either, because sender and receiver are of a unique frequency. A JF-Link system consists of a valve box and one or two remote controls. Either a tractor remote control *or* a hand remote control, or a tractor remote control *and* a hand remote control, or two hand remote controls. A valve box accepts only signals from one tractor remote control and one hand remote control, or two hand remote controls.

VALVE BOX

Fig. 1.1 The valve box is mounted on the machine and connected to the solenoid valves that control the hydraulic components. The valve box must be connected to 12V and is secured by a fuse (A) of maximum 10A.



To avoid flattening the battery the power supply to the machine and the remote control should be connected to the tractor, so that the supply is interrupted when the tractor ignition is turned off.

Fig. 1.2 The valve box' power consumption is maximum 50 mA; add to this up to 2.5 A for each active solenoid valve. It is therefore important to switch off the current when the tractor motor has stopped.

1. JF-LINK WIRELESS ELECTRICAL OPERATION OF HYDRAUALICS

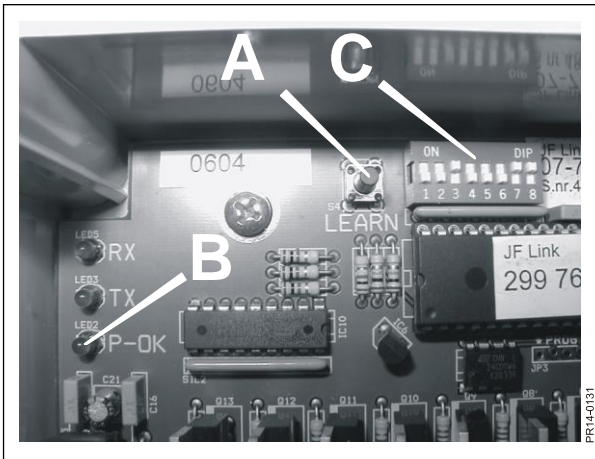

Fig. 1.3

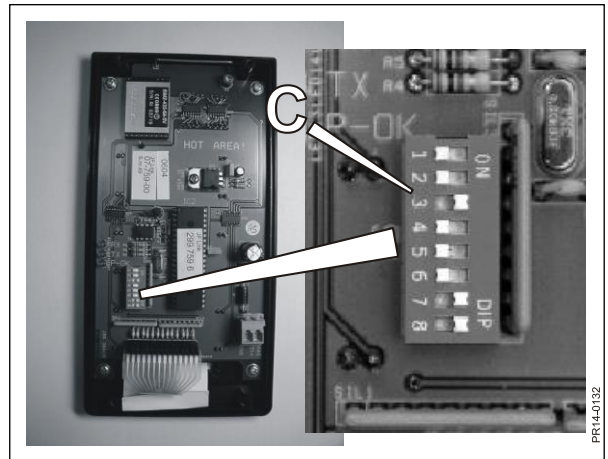

Fig. 1.4

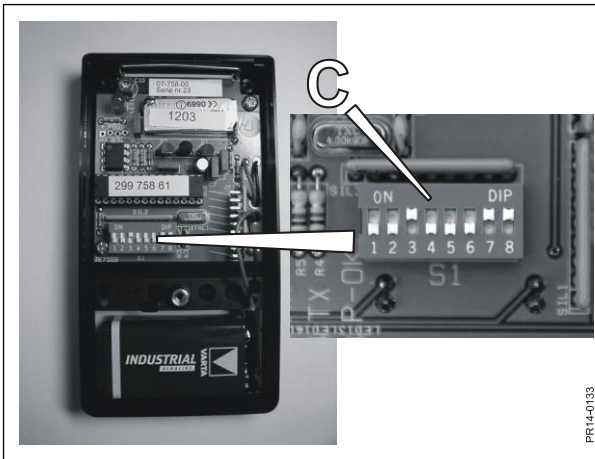

Fig. 1.5

PROGRAMMING OF REMOTE CONTROL

The safety in the system is based on the fact that maximum 2 remote controls, are identified by the valve box, are allowed to operate the hydraulic outlets. All remote controls during production are equipped with a unique (electronic) serial number used for identification.

Fig. 1.3 Programming of the remote control implies that all units in the system are set up to the same function variant on DIP1 – DIP4 (**C**). That is to say DIP1 – DIP4 must be set identically in the valve box and remote control(s) in order to communicate with each other.

Fig. 1.3 In order to program a new remote control the procedure below must be followed:

- 1) Check that the dips (**C**) are set identically.
- 2) Connect battery / power supply to the valve box and remote control(s).
- 3) Press the "LEARN"-button (**A**) in the valve box. LED "OK" (**B**) lights up constantly after approx. 3 seconds. Stop pressing the button.
- 4) Activate an arbitrary button on the remote control that is to be programmed / reported.
- 5) The constant light in LED "OK" goes out and a flash appears in all LEDs as during normal operation. The remote control is now programmed.

In case you want to delete programmed remote controls, push the "LEARN"-button for approx. 9 seconds. When the LED "OK" flashes, the 9 seconds are up and no remote controls can communicate with the valve box.

1. JF-LINK WIRELESS ELECTRICAL OPERATION OF HYDRAUALICS



Fig. 1.6

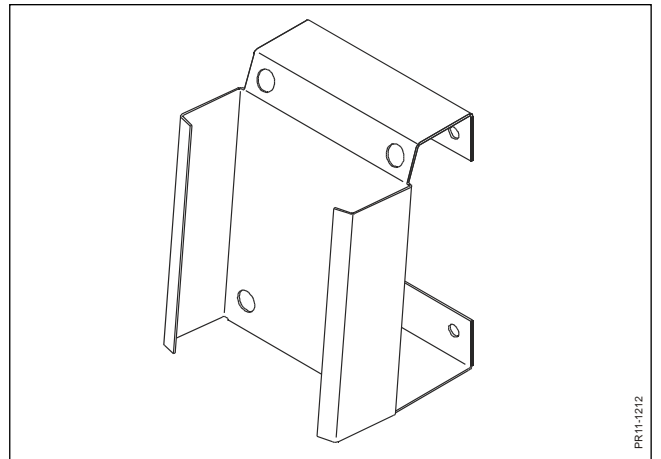

Fig. 1.7

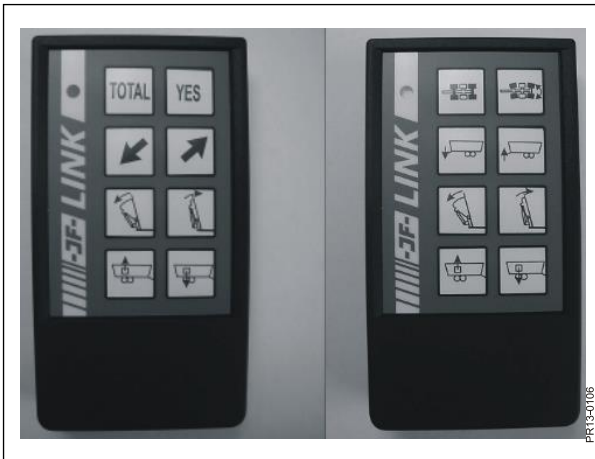

Fig. 1.8

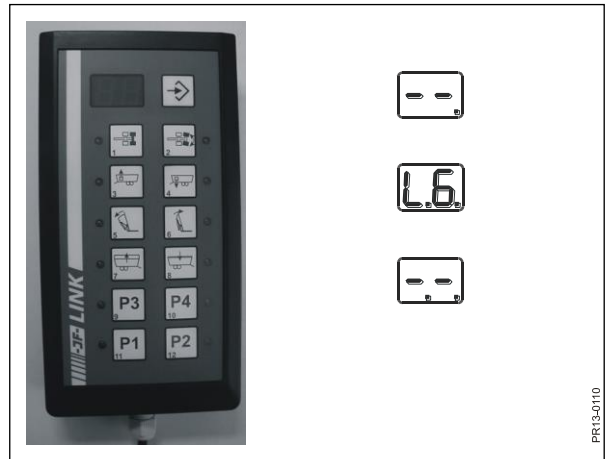

Fig. 1.9

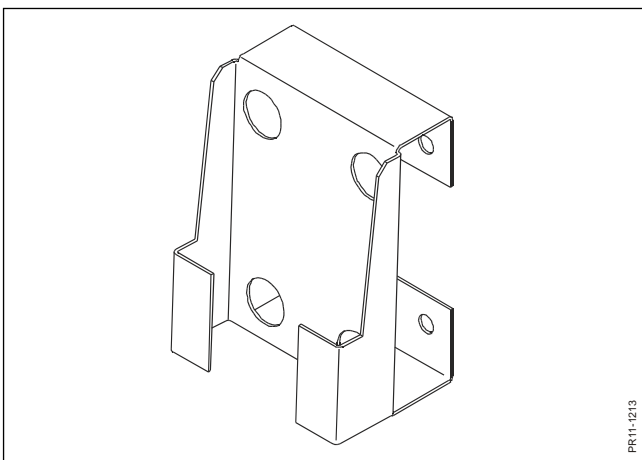

Fig. 1.10

REMOTE CONTROLS

TRACTOR REMOTE CONTROL



Fig. 1.6 The tractor remote control is intended for mounting in the tractor cabin.

Fig. 1.7 The included holder may be used for this purpose. The holder may carefully be adjusted to fit perfectly. The remote control must be connected to 12V (8-24V) through a fuse of max. 5A. Power consumption is up to 100 mA.

The remote control is supplied with a feedback function. The feedback function shows whether the communication between remote control and valve box works the way it should. When a button on the remote control is activated, a signal is sent to the valve box receiver. The receiver subsequently sends a signal back to the remote control and the light-emitting diode next to the button in question switches on to indicate that the communication succeeded.

Fig. 1.8 If a hand remote control is also used (see below) the valve box' feedback signals from the hand remote control will also be registered on the tractor remote control. You can thus see on the tractor remote control when the hand remote control is being used.

DISPLAY

Fig. 1.9 When starting up the display in the top left corner of JF-LINK shows:  When the first contact to the machine is established the display changes to showing proportional step e.g.: , however, only if proportional valve has been used on the machine.

The dot in the lower right corner on the display  is the "Power" indicator, which indicates that the remote is switched on.

The dot in the middle below:  follows the sending of data. Thus, here can be seen whether data is being sent.

HAND REMOTE CONTROL

Fig. 1.8 The hand remote control is supplied by 1 9V battery. The remote control can be used in the loader, from where potential hydraulic shearbars can be operated.

The remote control is produced in two versions. One version for 4 hydraulic functions (right) as well as a version for remote control of the weighing system for complete diet mixers and 2 hydraulic functions (left).

Fig. 1.10 The remote control is delivered with a holder that can be mounted in the tractor cabin.

1. JF-LINK WIRELESS ELECTRICAL OPERATION OF HYDRAUALICS



Fig. 1.11

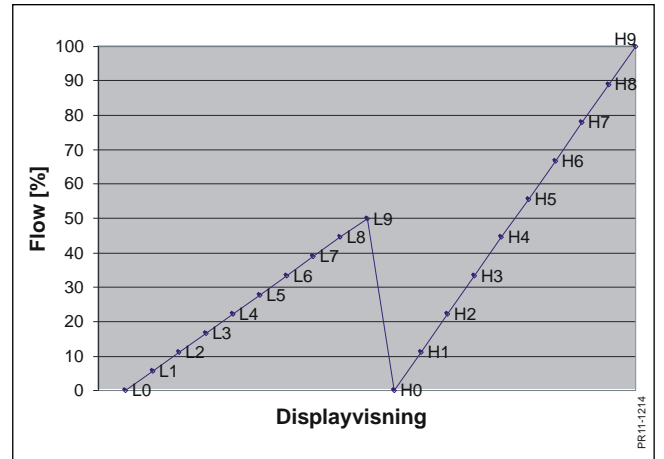

Fig. 1.12

FUNCTIONS

Below is a list of the functions that JF-Link can contain. What functions are on a given remote control depend on what machine it has been delivered for and the additional equipment that has been delivered with the machine.

The functions can control 4 different hydraulic components.

1. Single acting cylinders.
2. Double acting cylinders
3. Motors.
4. Proportional valves.

The operation is different according to what component is controlled and what machine part is activated.

PROPORTIONAL STEERING

Fig. 1.11 This function only exists on the tractor remote control. The function is used for adjustment of a motor's rpm. The adjustment takes place in a low and a high area each with 10 steps.

In the remote control display an **L** or an **H** is shown depending on what area is active.





The actual step is shown with a number: **0 – 9**. When pressing  the speed is increased one step, and when pressing  the speed is decreased one step. If a button is held down the steps shift continuously until the button is released.

Fig. 1.12 Speed area **L** goes from **L0** to **L9**. This area is intended for adjustment of slow motors i. e. for driving a conveyor chain. The amount of oil can be adjusted from 0 to approx. 50% of maximum oil amount. Area **H** goes from **H0** to **H9**. This area is used for high-speed motors i. e. for an unloading belt.

The speed areas **L** and **H** are in continuation of each other.

When pressing  and  at the same time, speed is increased to **H9** (maximum speed) until the buttons are released again. When the buttons are released the system returns to the step that was last active for 10 or more seconds.

1. JF-LINK WIRELESS ELECTRICAL OPERATION OF HYDRAUALICS

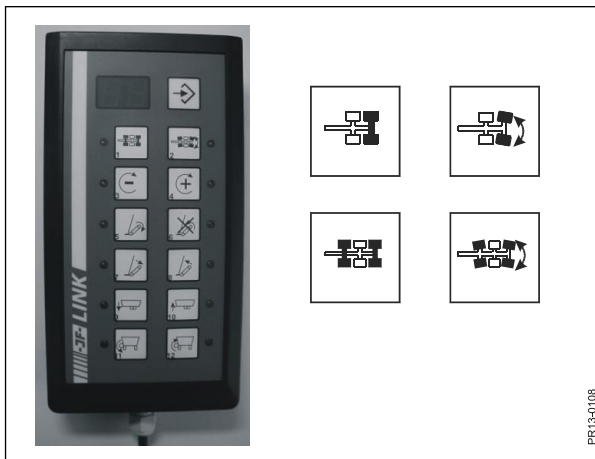



Fig. 1.13

BLOCKING OF AXLE WITH ARTICULATION

Fig. 1.13 This function is used for blocking and opening of articulated axles. Remember always to block the articulation before reversing the machine!

When pressing  for approx. 10 seconds, oil is sent to the articulation cylinder placing all tyres in parallel position. Depending on the ground and the load it may be necessary to put the wheels straight by driving forward.

Therefore it is not necessary to press the button for a longer time in order to make sure that the cylinders have reached the locking position.

Due to wear on tyres you should only reverse straight backwards; avoid as far as possible to turn and reverse at the same time.

Open the articulation by pressing  when driving forward again.



When speed exceeds 20 km/h we recommend blocking of the articulated axle!

MACRO PROGRAMS

These buttons can be programmed to carry out optional operation sequences. See more information about this in the section JF-Link Macro system.

2. MACRO SYSTEM

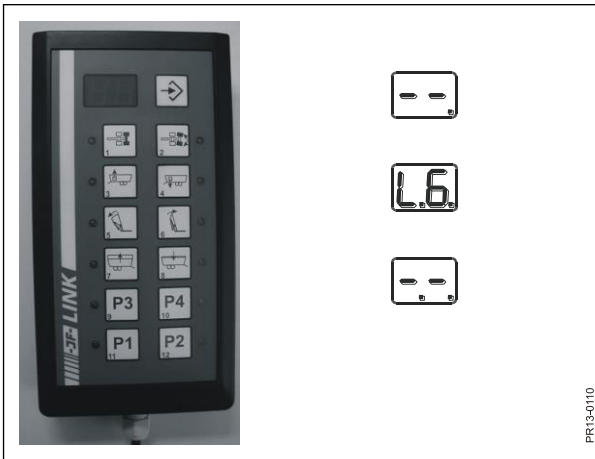

Fig. 2.1

2. MACRO SYSTEM

Fig. 2.1 The macro system allows programming of up to 4 operation sequences or programs consisting of up to 15 steps. The buttons that can be programmed are marked with **P**. (P1, P2 ...).

Programs are stored as "pressure" commands i.e. no regard is paid to the result of the action, just that it is carried out in the same period of time and in the same interval as it was programmed. In order for the programs to function correctly all cylinders must be in the same position when the program is executed as they were when it was programmed.

The only exception is a proportional valve. Here the program remembers what level it was set for, and not how many buttons that were pressed.

PROGRAMMING

Fig. 2.1 Press the programming button:  until the "P"-buttons start to flash. Press the "P"-button on which you would like the program to be stored. (Hereafter only this button will flash).

Carry out the desired sequence: Activate cylinders, start/stop motors etc.

When the desired sequence is carried out press the programming button:  and the program is saved and ready for use.

The program is now carried out every time the "P"-button in question is pressed. A program can be interrupted by pressing a *non* "P"-button.



REMEMBER: In order for the programs to work as intended, the cylinders that are operated by the program **must** be in the same position as immediately before the program was programmed.

If you would like the program to be changed, simply carry out a new programming as described above and the old program is deleted.

Programs are stored locally in the JF-Link remote control, and do not pay regard to the fact that settings are changed. If the machine is changed with one or more hydraulic functions, the programs must be re-programmed in order to work correctly. On the other hand, the programs can be used together with another machine with the same settings.

If the power is cut off during programming, the information will not be stored. Normally, the last programmed sequence is always remembered, no matter whether the power is on or not.

3. OPERATION VARIANTS

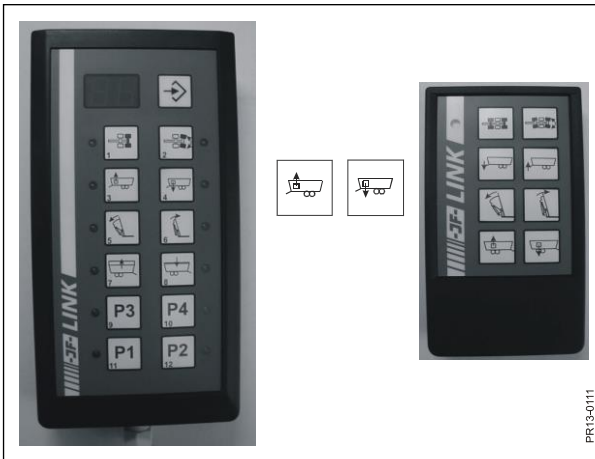

Fig. 3.1



Fig. 3.2

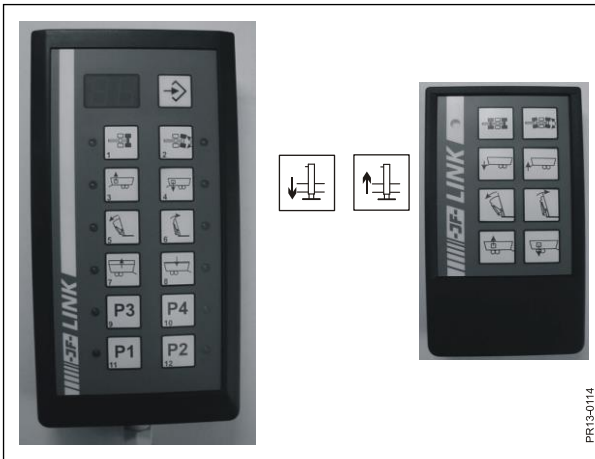

Fig. 3.3



Fig. 3.4

3. OPERATION VARIANTS

KONGSKILDE FEEDER COMPLETE DIET MIXERS "VM"

SIDE DOORS

Fig. 3.1 Is used to open and shut side doors. The drawing on the button indicates which side door on the machine this button controls.

Press  and the side door will open.

Press  and the side door will close.

The movement of the side doors will stop when the buttons are released.

HYDRAULIC SHEARBARS

Fig. 3.2 Control the shearbars in order to optimise the chopping degree. The shearbars will move as long as the buttons are pressed.

Press  and the shearbars will be pulled out.

Press  and the shearbars will be pushed in and make the chopping more aggressive.

HYDRAULIC JACK

Fig. 3.3 Is used to raise and lower the drawing eye by means of the hydraulic jack.

Press  and the drawing eye will be lowered.

Press  and the drawing eye will be raised.

The movements will stop when the buttons are released.

CROSS CONVEYOR

Fig. 3.4 Starts and stops the cross conveyor.

Press  to start the cross conveyor unloading to the right.

Press  to start the cross conveyor unloading to the left.

The cross conveyor will stop when one of the two buttons is pressed.

3. OPERATION VARIANTS

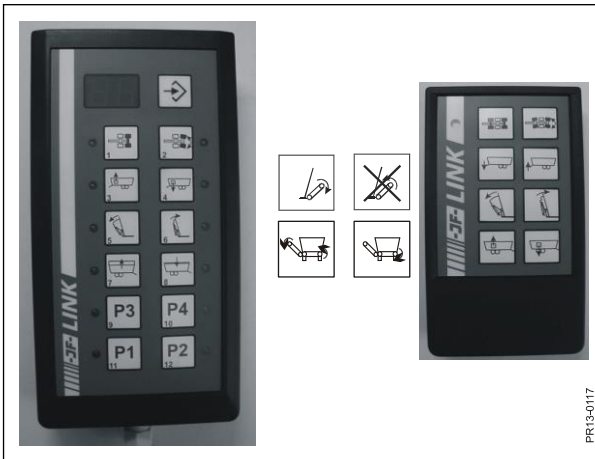

Fig. 3.5

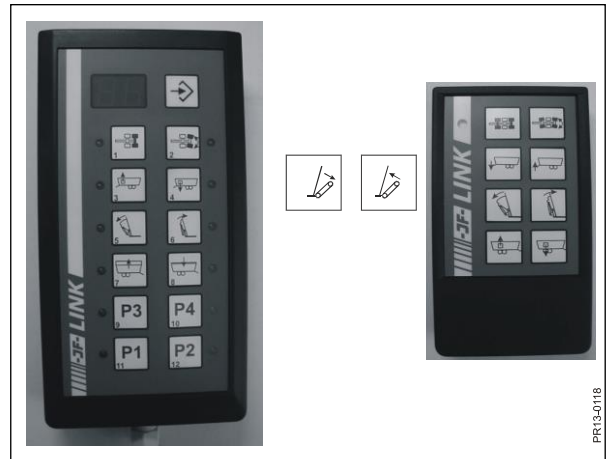

Fig. 3.6

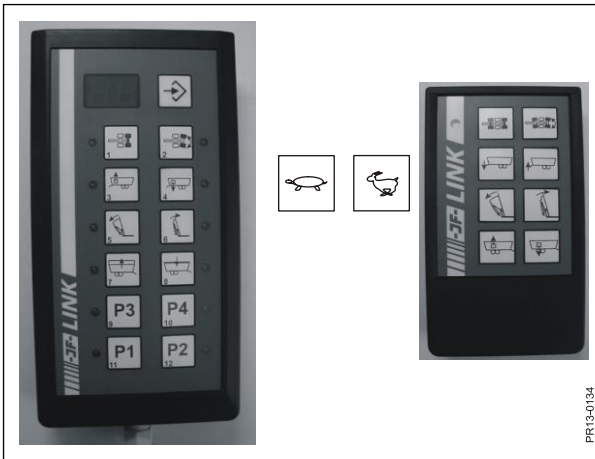

Fig. 3.7

3. OPERATION VARIANTS

ELEVATOR

Fig. 3.5 Starts and stops the unloading belt of the elevator.

Press  and the unloading belt will start.



The cross  means that the button should solely be used to repair a potential blockage. However, the unloading belt will stop if this button is pressed.

Fig. 3.6 Raises and lowers the elevator between unloading position and transport position.

Press  in order to lower the elevator into unloading position.

Press  in order to raise the elevator into transport position.

The movements will stop when the buttons are released.

GEAR CHANGE

Fig. 3.7 Changes gear on the reduction gear.

Press  in order to change down. Press the button until the indicator has reached the top. The PTO shaft must be activated in order for the gear to fall into place, if this has not already happened.

Press  in order to change up. Press the button until the indicator has reached the bottom. The PTO shaft must be activated in order for the gear to fall into place, if this has not already happened.

3. OPERATION VARIANTS

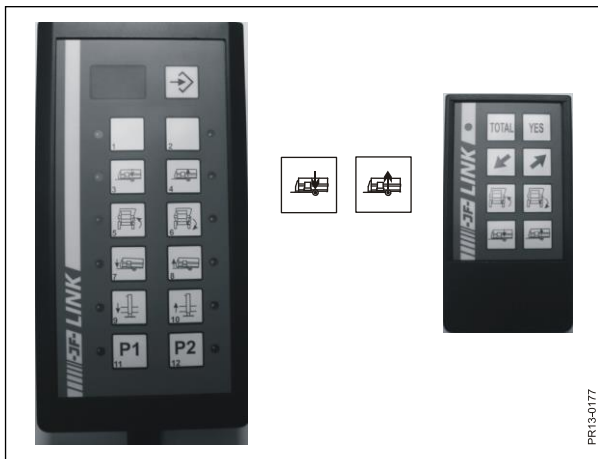

Fig. 3.8

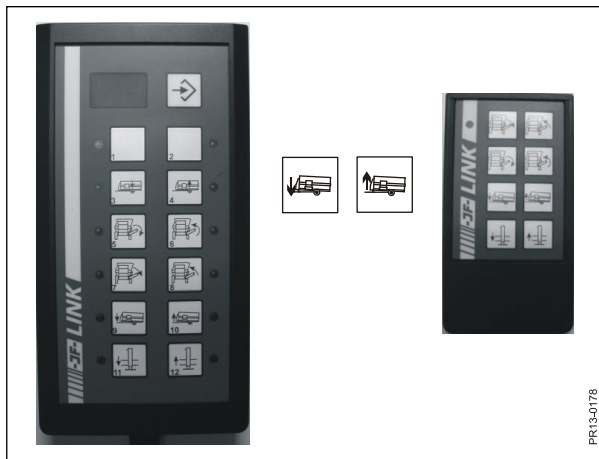

Fig. 3.9

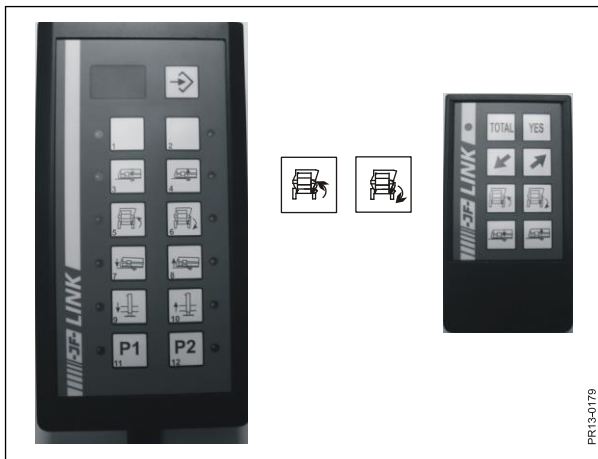

Fig. 3.10

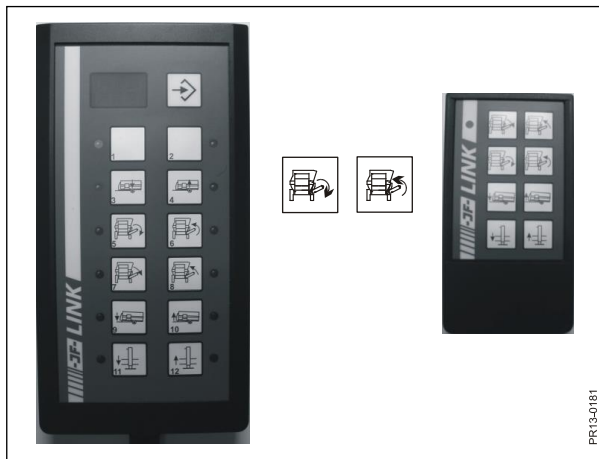

Fig. 3.11

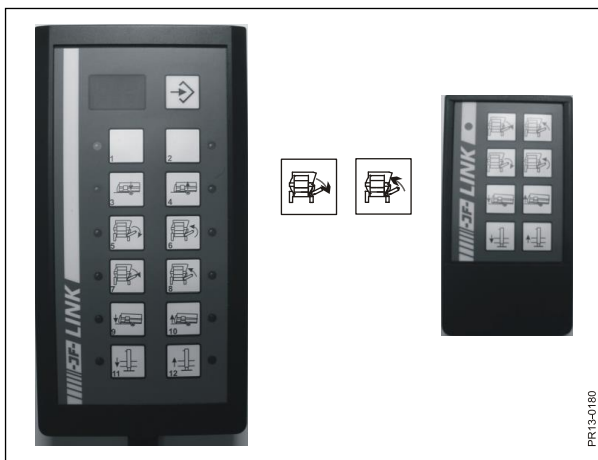

Fig. 3.12

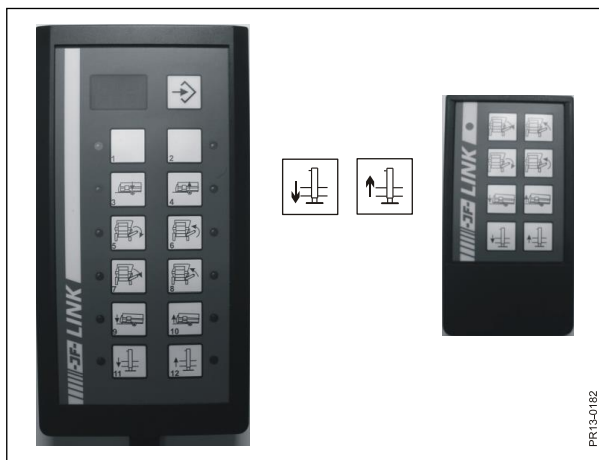



Fig. 3.13

KONGSKILDE FEEDER COMPLETE DIET MIXERS "PA"

SIDE DOOR

Fig. 3.8 Is used to open and shut the side door.

Press  and the side door will open.

Press  and the side door will close.

The movement of the side door will stop when the button is released.

HYDRAULIC TIPPING OF TUB

Fig. 3.9 This function is used to adjust the tub to horizontal position, or to lower the tub a little, when it is almost empty in connection with discharge.

Press  and the front end of the tub is tipped downwards.

Press  and the front end of the tub is tipped upwards.

DISCHARGE WITH ROLLER

Fig. 3.10 Starts and stops the roller under the side door.

Press  and the roller will start.

Press  and the roller will stop. The roller should only turn backwards for a short period, to avoid risk of blockage.

ELEVATOR

Fig. 3.11 Starts and stops the unloading belt of the elevator.

Press  and the unloading belt will start.



The cross  means that the button should solely be used to repair a potential blockage. However, the unloading belt will stop if this button is pressed.

Fig. 3.12 Raises and lowers the elevator between unloading position and transport position.

Press  in order to lower the elevator into unloading position.

Press  in order to raise the elevator into transport position.

The movements will stop when the buttons are released.

HYDRAULIC JACK

Fig. 3.13 Is used to raise and lower the drawing eye by means of the hydraulic jack.

Press  and the drawing eye will be lowered.

Press  and the drawing eye will be raised.

The movements will stop when the buttons are released.

4. MISCELLANEOUS

INTERRUPTIONS

| PROBLEM | POSSIBLE CAUSE | ACTION |
|--|---|--|
| No light in the remote control | The battery is flat. | Change the battery. |
| No reaction when buttons are pressed. | Poor signal communication. | Radio noise source close by must be turned off. |
| The battery is being flattened. | There is power on the valve box. The function "articulation unlocked" and the proportional valve (except from the positions L0 and H0) are permanent current-consumers. | Cut off the power to the valve box when the tractor is not running. |
| When the button on the remote control is released the function continues for a little while. | Due to the safe wireless communication there is a delay of approx. 0.3 seconds. | Nozzles/throttle pieces can be used in order to make the function move slower. There are 2 versions: 2010-394x (ø 1.5) and 2307-111x (ø 0.8) |
| | | |

HYDRAULIC DIAGRAM

For hydraulic diagram of the valves, please see instruction manual.

EF-overensstemmelseserklæring/ EG-Konformitætserklæring/ EC Declaration of Conformity/ Déclaration CE de conformité/ Dichiarazione CE di conformità/ EG Verklaring van Overeenstemming/ EG-försäkran om överensstämmelse/ EY-vaatimustenmukaisuusvakuutus/ Declaración de conformidad CE/ Deklaracja Zgodności WE./ Декларация за съответствие EO/ EK Megfelelőségi Nyilatkozat /ES Prohlášení o shodě/ EB Atitikties deklaracija/ ES prehlásenie o zhode/ Declarația de conformitate CE/ Vastavuse Deklaratsioon EÜ /ES Izjava o skladnosti/ Δήλωση πιστότητας EK/ Declaração de fidelidade CE/ Dikjarazzjoni ta' Konformità tal-KE/ EK Atbilstības deklarācija/

Fabrikant/ Hersteller/ Manufacturer/ Fabricant/ Produttore/ Fabrikant/ Fabrikant/ Valmistaja/ Fabricante/ Producent/ Производител/ Gyártó/ Výrobce/ Gamintojas/ Výrobca/ Producător/ Tootja/ Proizvajalec/ Κατασκευαστής/ Fabricante/ Fabbrikant/ Ražotājs

CNH INDUSTRIAL BELGIUM N.V.

Leon Claeyssstraat 3a, 8210 Zedelgem, BELGIUM

Repræsenteret af Antoon Vermeulen, Leon Claeyssstraat 3A, B8210 Zedelgem (Belgien), som også har tilladelse til at indsamle teknisk dokumentation / vertreten durch Antoon Vermeulen, Leon Claeyssstraat 3A, B8210 Zedelgem (Belgium), der auch autorisiert ist, die technische Akte zu erarbeiten / represented by Antoon Vermeulen, Leon Claeyssstraat 3A, B8210 Zedelgem (Belgium), who is also authorised to compile the Technical File / Réprésentés par Antoon Vermeulen, Leon Claeyssstraat 3A, B8210 Zedelgem (Belgique), également autorisé à constituer le dossier technique / rappresentati da Antoon Vermeulen, Leon Claeyssstraat 3A, B8210 Zedelgem (Belgio), autorizzato a compilare il File tecnico / vertegenwoordigd door Antoon Vermeulen, Leon Claeyssstraat 3A, B8210 Zedelgem (Belgium), die tevens is gemachtigd om het Technisch Bestand samen te stellen / representerade av Antoon Vermeulen, Leon Claeyssstraat 3A, B8210 Zedelgem (Belgien), som också har behörighet att sammanställa den tekniska dokumentationen / edustajamme Antoon Vermeulenin, osoite Leon Claeyssstraat 3A, B8210 Zedelgem (Belgium) välityksellä, jolla on myös oikeus laatia tekninen tiedosto / representados por Antoon Vermeulen, Leon Claeyssstraat 3A, B8210 Zedelgem (Bélgica), quien además está autorizado para recopilar el documento técnico / której przedstawicielem jest Antoon Vermeulen, Leon Claeyssstraat 3A, B8210 Zedelgem (Belgia), który jest również upoważniony do sporządzenia dokumentacji technicznej / представлявани от Антоон Вермеулен, Leon Claeyssstraat 3A, B8210 Zedelgem (Белгия), с упълномощение също да състави Техническото досие / akiket képvisel: Antoon Vermeulen, Leon Claeyssstraat 3A, B8210 Zedelgem (Belgium), aki szintén jogosult a műszaki dokumentumok összeállítására / v zastoupení Antoon Vermeulen, Leon Claeyssstraat 3A, B8210 Zedelgem (Belgium), s autorizací k tvorbě technického souboru / atstovaujami Antoon Vermeulen, Leon Claeyssstraat 3A, B8210 Zedelgem (Belgija), taip pat turintis teisę sudaryti technines bylas / v zastúpení Antoonom Vermeulenom, Leon Claeyssstraat 3A, B8210 Zedelgem (Belgicko), ktorý je oprávnený zostavovať technickú dokumentáciu / reprezentati de Antoon Vermeulen, Leon Claeyssstraat 3A, B8210 Zedelgem (Belgia), care este, de asemenea, autorizat să compileze dosarul tehnic / esindajatega Antoon Vermeulen, Leon Claeyssstraat 3A, B8210 Zedelgem (Belgia), kellel on samuti luba tehnilise faili koostamiseks / ki nas zastopa Antoon Vermeulen, Leon Claeyssstraat 3A, B8210 Zedelgem (Belgija), ki je pooblaščen tudi za sestavo tehnične dokumentacije / εκπροσωπούμενοι από τον Antoon Vermeulen, Leon Claeyssstraat 3A, B8210 Zedelgem (Βέλγιο), με εξουσιοδότηση και για τη σύνταξη του Τεχνικού φακέλου / representados por Antoon Vermeulen, Leon Claeyssstraat 3A, B8210 Zedelgem (Bélgica), que também tem autorização para compilar o Ficheiro Técnico / irraþrezentata minn Antoon Vermeulen Leon Claeyssstraat 3a, B8210 Zedelgem (Belgju), min huwa wkoll awtoriztat li tiġbor l-Fajl Tekniku / Antoon Vermeulen, Leon Claeyssstraat 3A, B8210, Zedelgem (Belgium), pārstāvēti, kas ir pilnvarots arī sastādīt tehnisko reģistru

Erklærer hermed, at/ Erklären hiermit, daß/ Hereby declare that/ Déclare par la présente que/ Dichiaro che/ Verklaren hierbij dat/ Försäkrar härmed, att/ Vakuuttaa täten, että tuote/ Por el presente declara que/ Niniejszym deklaruje, że/ Декларирам, че/ Az alábbiakban kijelentem, hogy/ Tímto prohlašuje, že/ Deklaruoja, kad/ Týmto prehlasujeme, že/ Prin prezenta declar că/ Alljärgnevaga deklareerib, et/ Izjavljamo, da je/ Με το παρόν δηλώνω ότι/ Abaixo declara que / Jiddikjaraw li / Apstiprinu, ka

| | | |
|--------------|-------------|-----------|
| Maskine: | La máquina: | Masin: |
| Maschine: | Maszyna: | Stroj: |
| Machine: | Машината: | Η μηχανή: |
| Machine: | Gép: | Máquina: |
| La macchina: | Stroj: | Il-magna: |
| Machine: | Mašina: | Mašina: |
| Maskin: | | Stroj: |
| Laite: | | Mašina: |



Model/Type: **JF-Link**

Designation: Mixer

Serial:

- er i overensstemmelse med Maskindirektivets bestemmelser (Direktiv 2006/42/EF) og hvis relevant også bestemmelserne i EMC-direktivet 2014/30/EU.

- In übereinstimmung mit den Bestimmungen der Maschinen-Richtlinie 2006/42/EG und wenn erforderlich auch mit der EMC-Richtlinie 2014/30/EU hergestellt wurde.

- is in conformity with the provisions of the Machinery Directive 2006/42/EC and if relevant also the provisions of the EMC Directive 2014/30/EU.

- est conforme aux dispositions de la Directive relatives aux machines 2006/42/CE et également aux dispositions de la Directive sur la Directive EMC 2014/30/UE.
- é in conformita' con la Direttiva Macchine 2006/42/CE e, se pertinente, anche alla Direttiva alla Direttiva EMC 2014/30/UE.
- in overeenstemming is met de bepalingen van de Machine richtlijn 2006/42/EG en wanneer relevant ook met de bepalingen van de EMC richtlijn 2014/30/UE.
- är i överensstämmelse med Maskindirektivets bestämmelser (Direktiv 2006/42/EG) ock om relevant också bestämmelserna EMC-direktivet 2014/30/UE.
- täyttää Konedirektiivin (Direktiivi 2006/42/EY) määräykset ja oleellisilta osin myös EMC-direktiivin 2014/30/UE.
- es conforme a la Directiva de Maquinaria 2006/42/CE y, si aplica, es conforme también a la Directiva EMC 2014/30/UE.
- pozostaje w zgodzie z warunkami Dyrektywy Maszynowej 2006/42/WE i jeżeli ma to zastosowanie również z warunkami Dyrektywy dot. kompatybilności elektro magnetycznej EMC 2014/30/UE.
- отговаря на изискванията на Директивата за Машините 2006/42/ЕО и ако има приложение на изискванията на Директивата за електромагнитна съвместимост 2014/30/ЕС.
- Megfelel a 2006/42/EK Gépi Eszközökre vonatkozó előírásoknak és amennyiben felhasználásra kerül, a 2014/30/UE Elektromágneses kompatibilitás Irányelv feltételeinek.
- odpovídá základním požadavkům Strojní směrnice 2006/42/ES a jestliže to její uplatnění vyžaduje i s podmínkami Směrnice 2014/30/UE týkající se elektromagnetické kompatibility.
- atitinka Mašinų direktyvos Nr. 2006/42/EB ir, jeigu taikoma, Elektromagnetinio suderinamumo direktyvos Nr. 2014/30/ES reikalavimus.
- je v súlade s podmienkami Smernice 2006/42/ES o strojných zariadeniach a pokiaľ si to jeho uplatnenie vyžaduje aj s podmienkami Smernice 2014/30/EÚ o elektromagnetickej kompatibilite.
- îndeplineşte prevederilor Directivei de Maşini 2006/42/CE şi dacă este utilizată de asemenea cu prevederile Directivei referitoare la compatibilitatea electro-magnetică EMC 2014/30/UE.
- on vastavuses Masinate Direktiivi tingimustega 2006/42/EÜ ning sammuti juhul, kui on tegemist sammuti on vastavuses Elektromagnetilise kokkusobivuse Direktiivitingimustega EMC 2014/30/EL.
- z določili Direktive o strojih 2006/42/ES ter, če je to relevantno, tudi z določili EMC Direktive 2014/30/UE.
- παραμένει σύμφωνη με τους όρους της Οδηγίας περί Μηχανών 2006/42/EK και σε περίπτωση που αυτό εφαρμόζεται και με τους όρους της Οδηγίας περί ηλεκτρομαγνητικής συμβατότητας (ΗΜΣ) 2014/30/ΕΕ.
- Está de acordo com exigências das Directivas das Maquinarias 2006/42/CE e no caso em que tiver igualmente aplicação com as exigências das Directivas referentes a compatibilidade electromagnética EMC 2014/30/UE.
- tikkonforma mad-dispożizzjonijiet tad-Direttiva dwar il-Makkinarju 2006/42/KE u jekk rilevanti wkoll mad-dispożizzjonijiet tad d-Direttiva EMC 2014/30/UE.
- atbilst mašīnu direktīvai 2006/42/EK, kā arī nepieciešamības gadījumā elektromagnētiskās saderības direktīvai EMC 2014/30/ES.

Zedelgem, date:

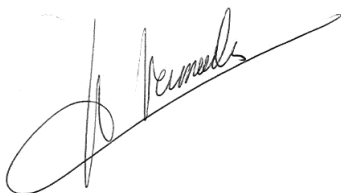

Antoon Vermeulen

Dealer's stamp

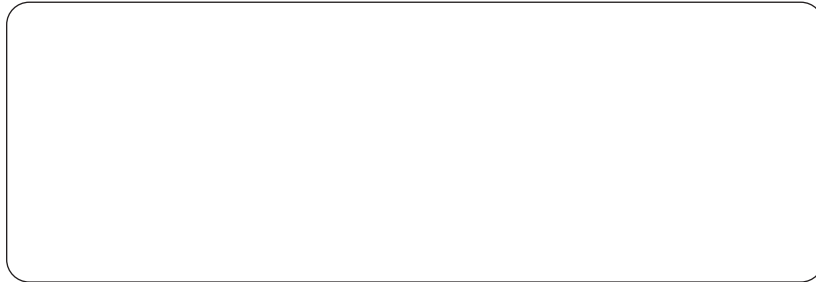

CNH Industrial Belgium N.V. reserves the right to make improvements in design and changes in specifications at any time without notice and without incurring any obligation to install them on units previously sold. Specifications, descriptions, and illustrative material herein are as accurate as known at time of publication, but are subject to change without notice.

Availability of some models and equipment builds varies according to the country in which the equipment is being used. For exact information about any particular product, please consult your Kongskilde dealer.



© 2018 CNH Industrial Belgium N.V. All Rights Reserved.

Kongskilde is a trademark registered in the United States and many other countries, owned by or licensed to CNH Industrial N.V., its subsidiaries or affiliates.

Any trademarks referred to herein, in association with goods and/or services of companies, other than owned by or licensed to CNH Industrial N.V., its subsidiaries or affiliates, are the property of those respective companies.