



# Basiseinstellungen für Mähwerke

## Index

GD 2800-3205 FM, GD 3205 F .....	2
GXF 3205-3605 P .....	2
CM 265-305F .....	2
GX 2402-3202 / SM, 2405-3205 / SM, CM 305 .....	3
GX 7005, GX 9005, GX 9005 SM .....	3
SB 200-240, SB 2402-2802, CM 170-190 .....	3
SM 2805, SM 3205 .....	4
GMS 2800-3600 FLEX/TS, GMS 2802-3202 FLEX/TS, GMS 280/320, GFS 3205 FLEX/TS ..	5
GMT 3205-3605 FLEX P/R/S .....	6
GMS 4802 In Line / Dual Line .....	7
GXT 12005 / 12005 SM / 13005 P / 15005 SM .....	8

## Basiseinstellungen für Mähwerke

**GD 2800-3205 FM, GD 3205 F**

PTO = 1000 rpm

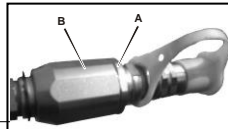

Die Hubgeschwindigkeit kann mittels Drosselventil eingestellt werden.

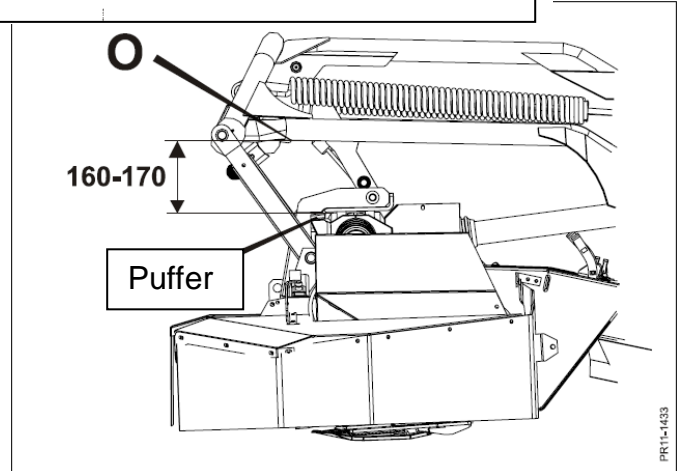
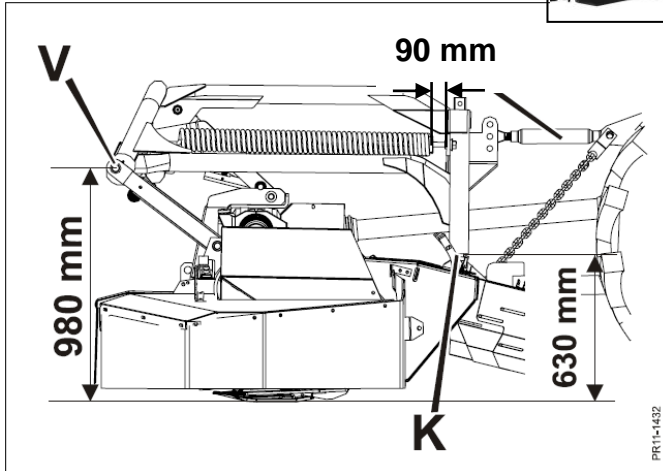

**GXF 3205-3605 P**

PTO = 1000 rpm

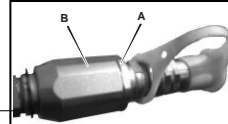

Die Senkgeschwindigkeit kann mittels Drosselventil eingestellt werden

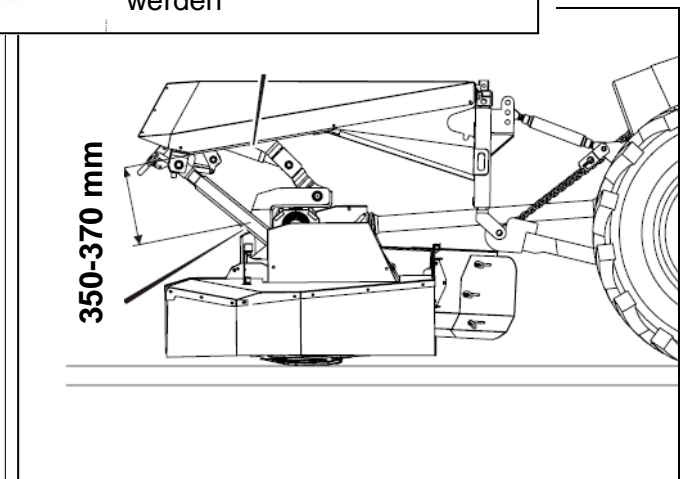
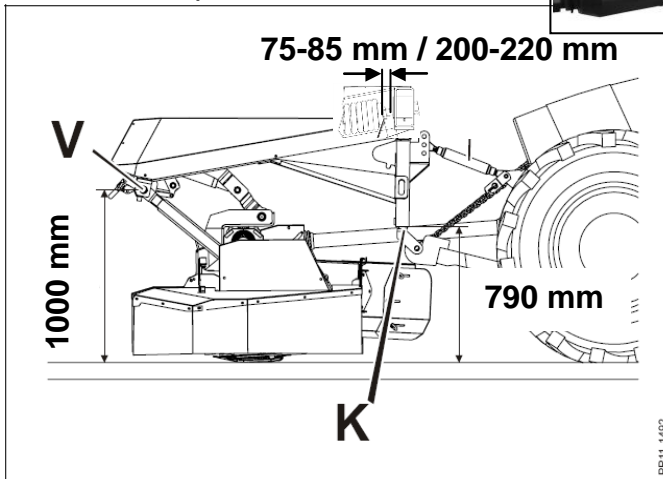

**CM 265-305F**

PTO = 1000 rpm

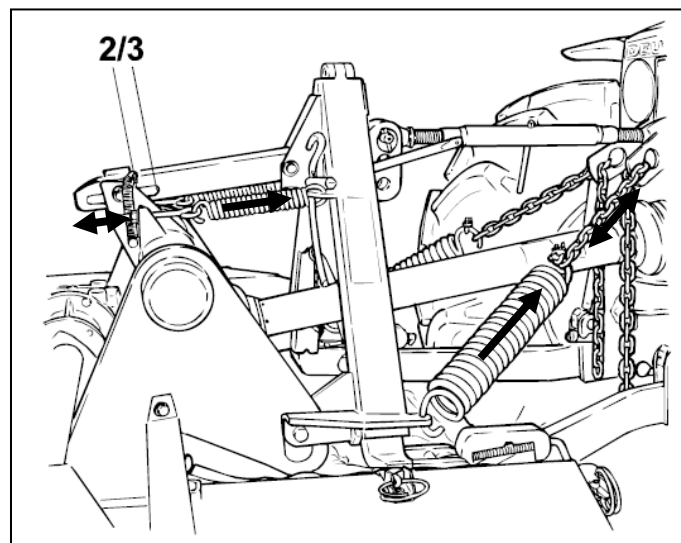

## Basiseinstellungen für Maschinen

**GX 2402-3202 / SM, 2405-3205 / SM, CM 305**

PTO = 540 / 1000 rpm

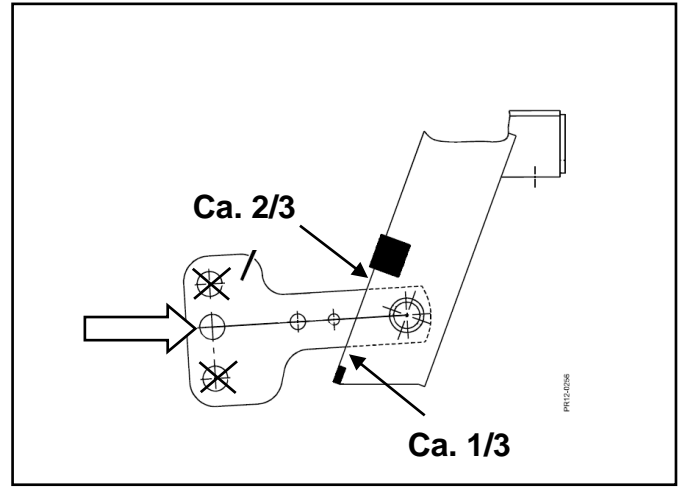
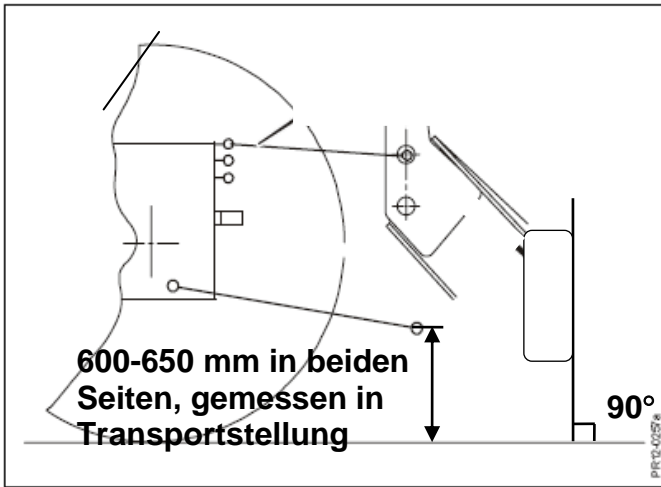

**GX 7005, GX 9005, GX 9005 SM**

PTO = 1000 rpm

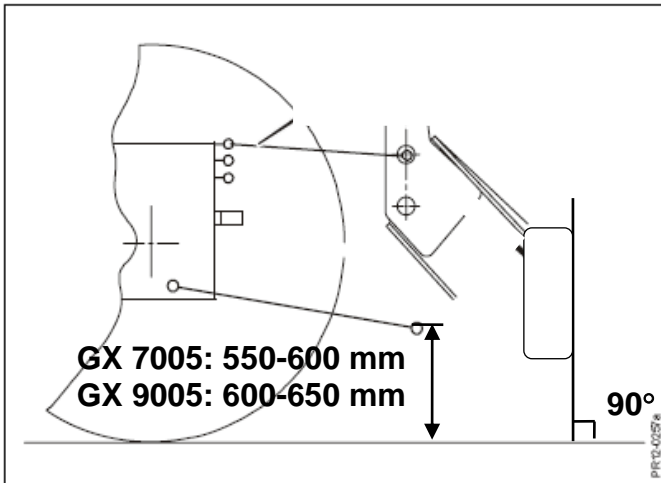

**SB 200-240, SB 2402-2802, CM 170-190**

PTO 540 rpm

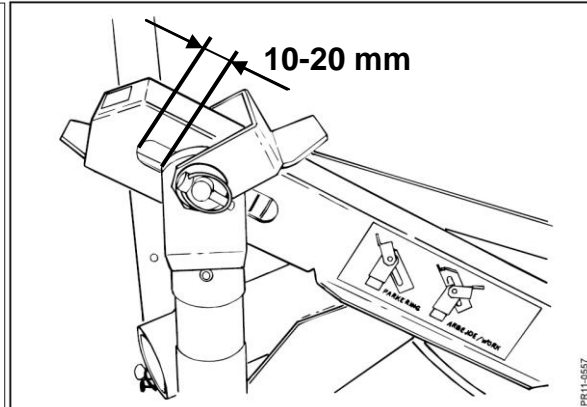
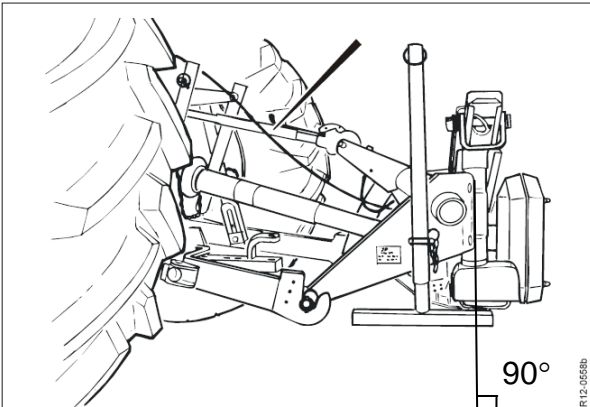



# SM 2805, SM 3205

PTO = 540 rpm

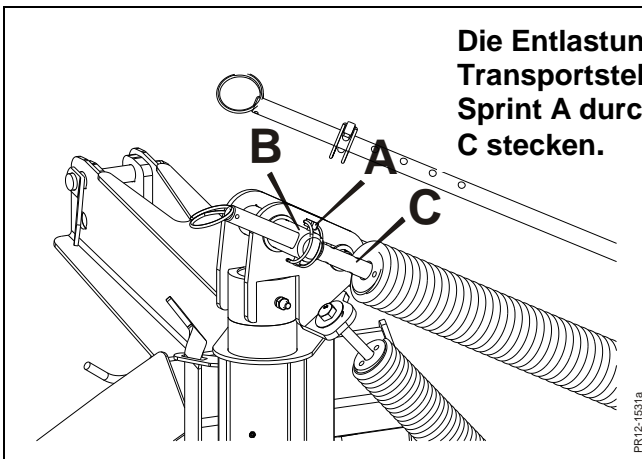
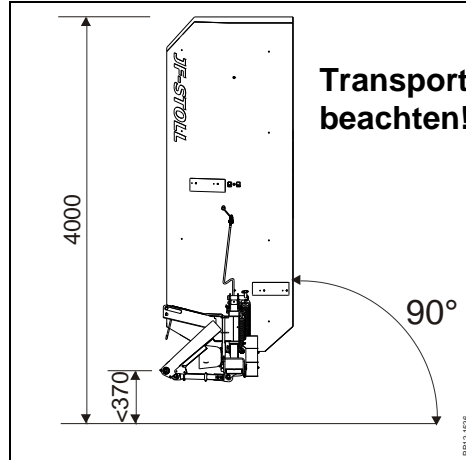
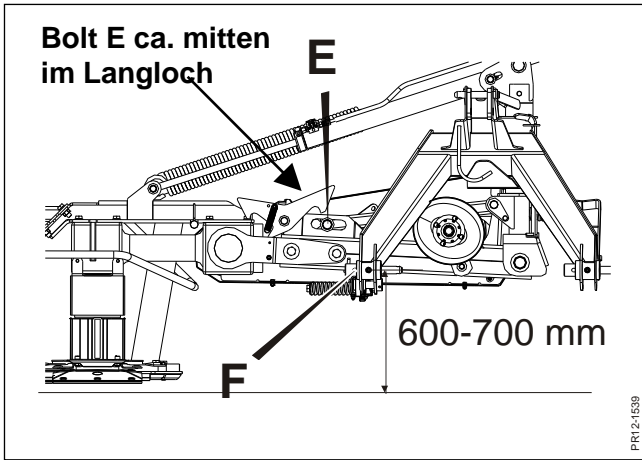

**GMS 2800-3600 FLEX/TS, GMS 2802-3202 FLEX/TS, GMS 280/320, GFS 3205 FLEX/TS**

PTO = 1000 rpm / (540 rpm)

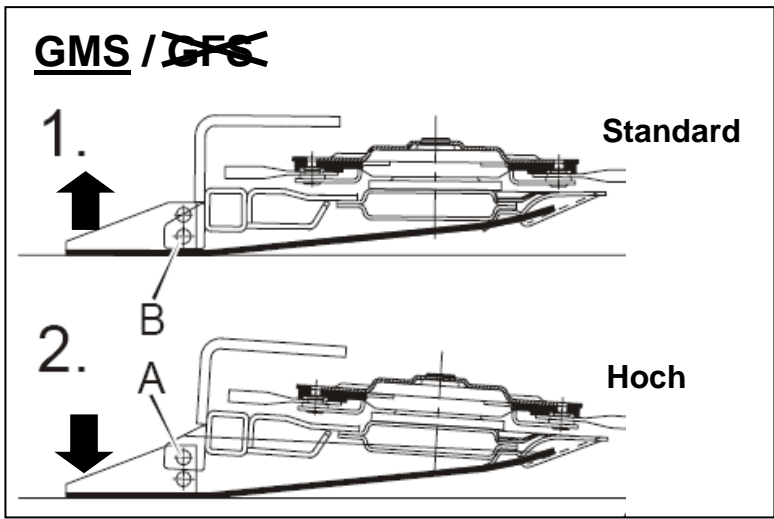
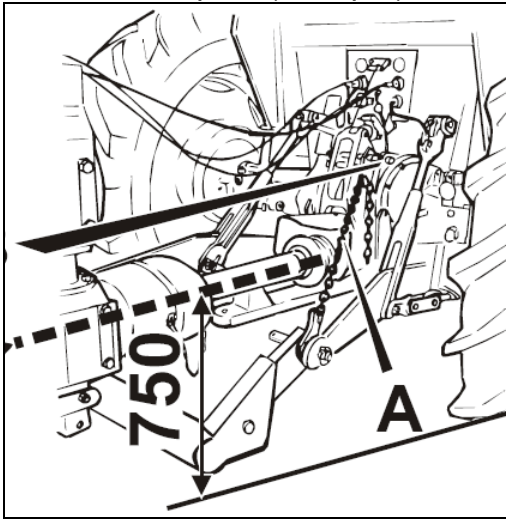

Die Einstellung erfolgt mit der Zugdeichsel in Mittelposition und mit abgesenktem Schneidwerk

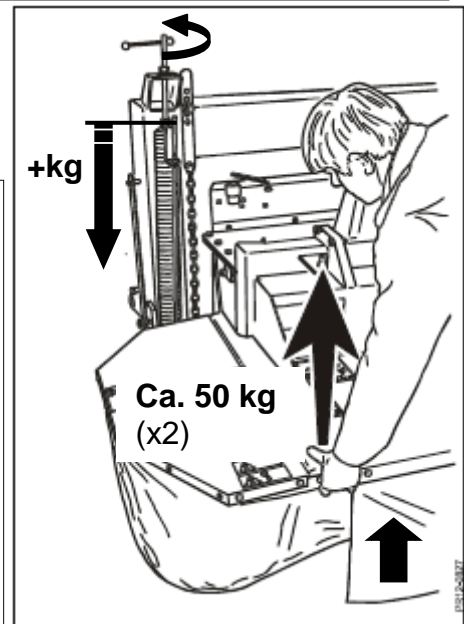
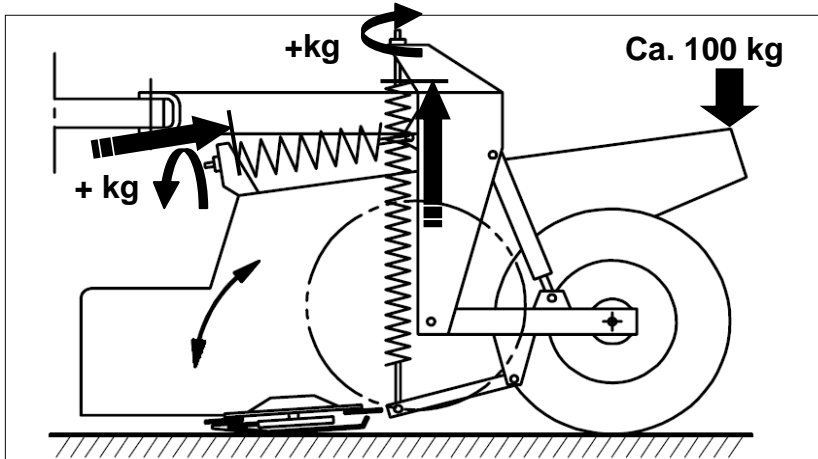

**GMT 3205-3605 FLEX P/R/S**

PTO = 1000 rpm

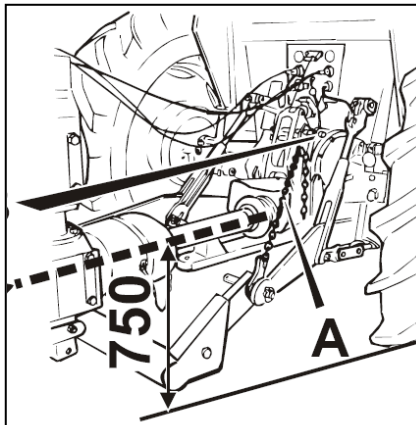

Die Einstellung erfolgt mit der Zugdeichsel in Mittelposition und mit abgesenktem Schneidwerk

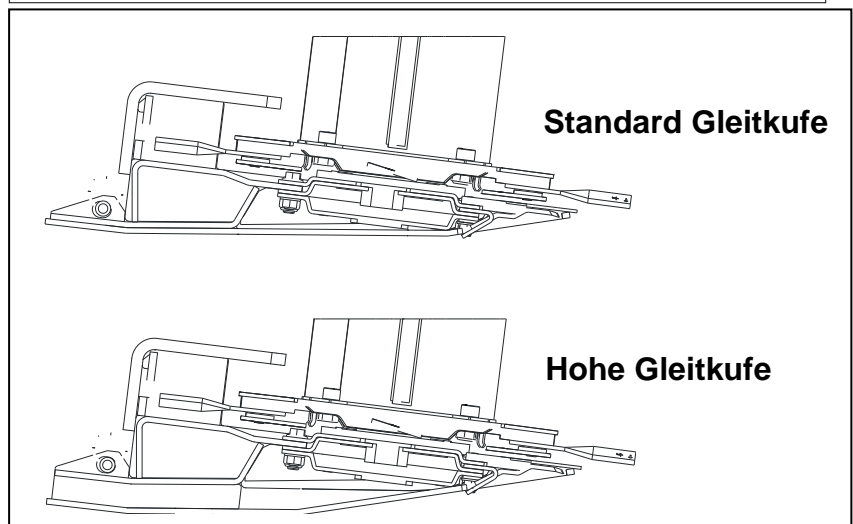
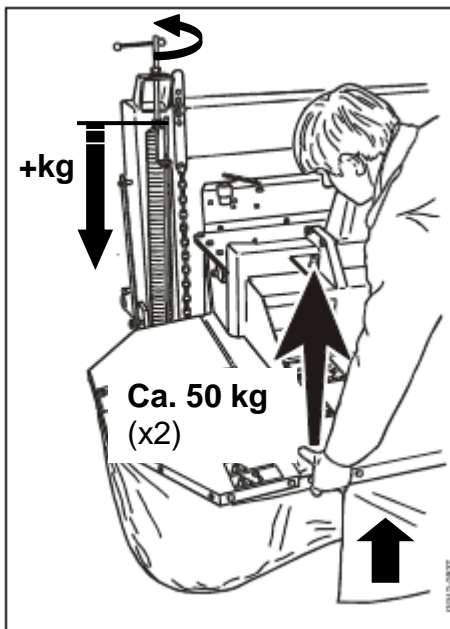
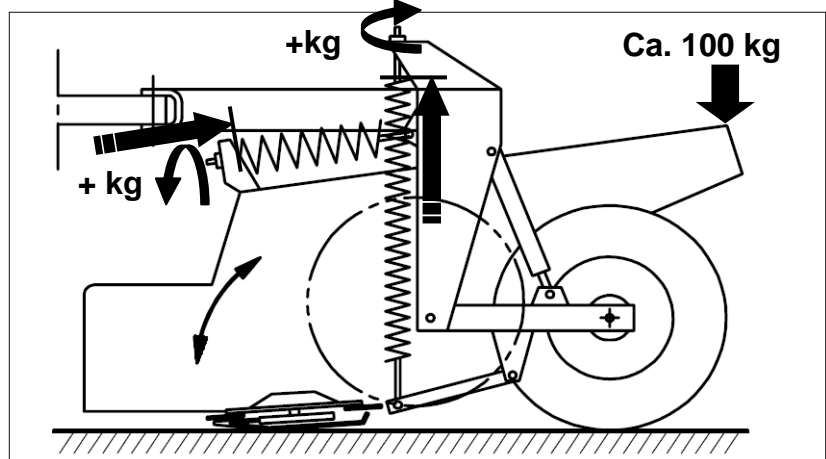



# GMS 4802 In Line / Dual Line

PTO = 1000 rpm

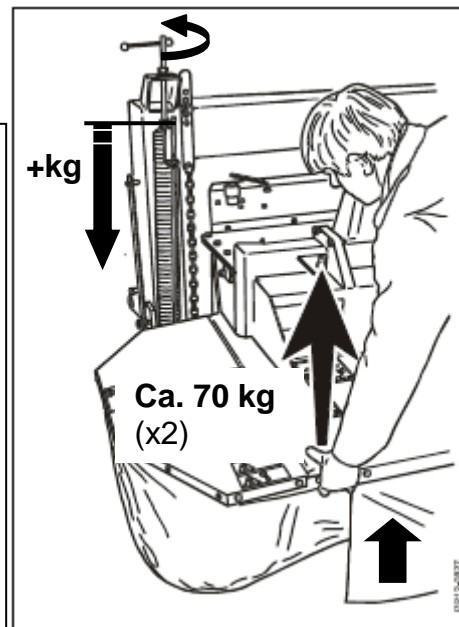
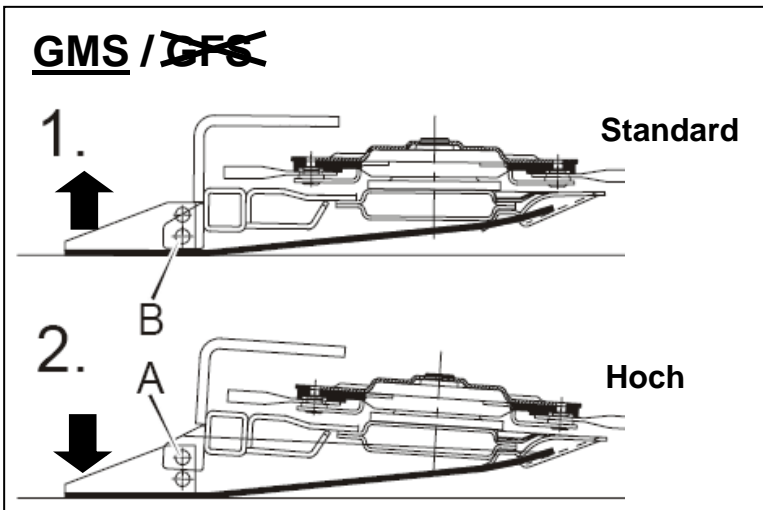
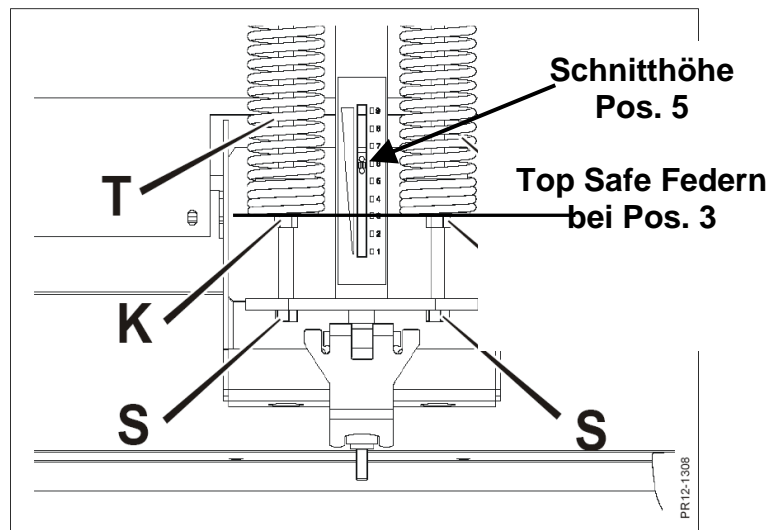
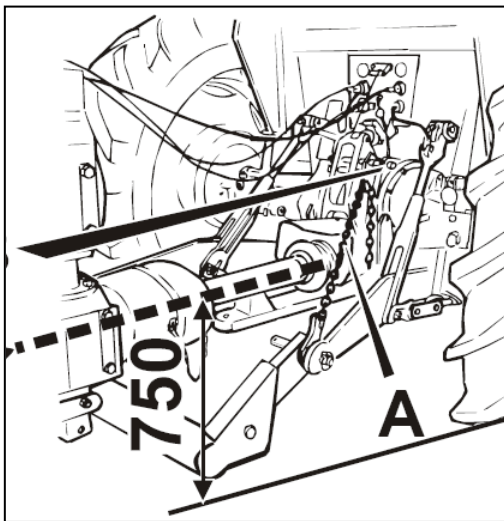



**GXT 12005 / 12005 SM / 13005 P / 15005 SM**

PTO =1000 rpm

